

Flashing Beacon 202

(provisional technical data sheet)

WERMA Signaltechnik
GmbH + Co. KG
Dürbheimer Straße 15
78604 Rietheim-Weilheim
Phone 07424 / 9557-0
Fax 07424 / 9557-44
info@werma.de

Electrical specifications:

Operating voltage: Unenn = see order data

Current consumption:

202 #00 55 Flashing beacon (<100mA DC)

202 #00 67 Flashing beacon (< 20mA AC)

202 #00 68 Flashing beacon (< 30mA AC)

Order No.:

202 #00 55 Flashing beacon 24V DC

202 #00 67 Flashing beacon 115V AC

202 #00 68 Flashing beacon 230V AC

1 = red 2 = green 3 = yellow 4 = clear
5 = blue

Mechanical specifications:

Material:

- Cap: PC
- Adapter ring: PC, black
- Base: PA6.6 glass fiber reinforced, black

Further specifications:

Weight: approx 82g

Temperature: ta -20°C up to +50°C

Protection degree: IP65 when mounted

Terminal version: Screwless CAGE
CLAMP®-technology
up to 2,5 mm² max.

Cable outlet: Downwards

Regulations: Conform to current
EC-regulations / UL listed

CAGE CLAMP® is a registered trade mark of
WAGO Kontakttechnik GmbH

Note: All electrical and working life specifications refer to Unenn!

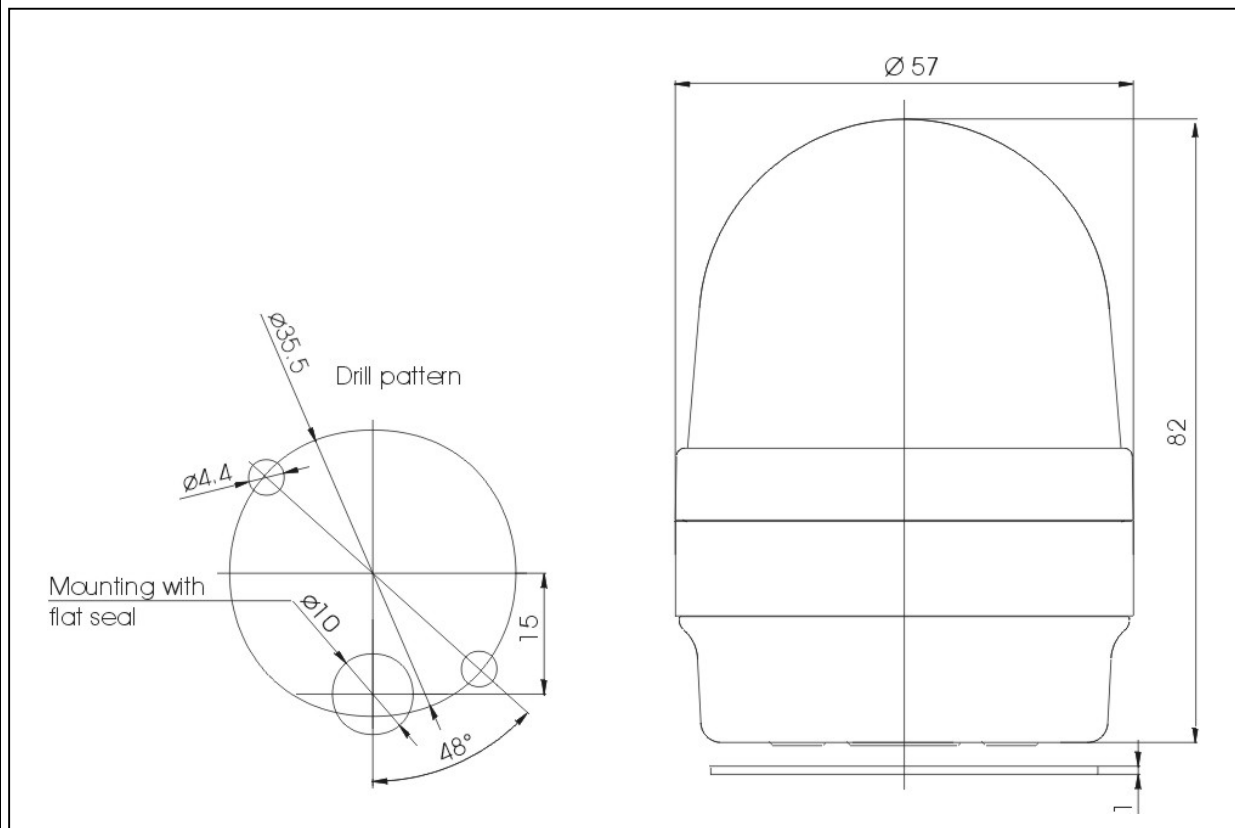

	Drawn up	proved	released	Data-sheet-No.
Name	E. Degen	S. Rudischhauser	H. Elsäßer	000 202 501
Date	2002-05-15	2002-05-16	2002-05-16	Page 1 of 1